

Centralizers

KUDU Sucker Rod Centralizers

Eliminate Rod Coupling Wear

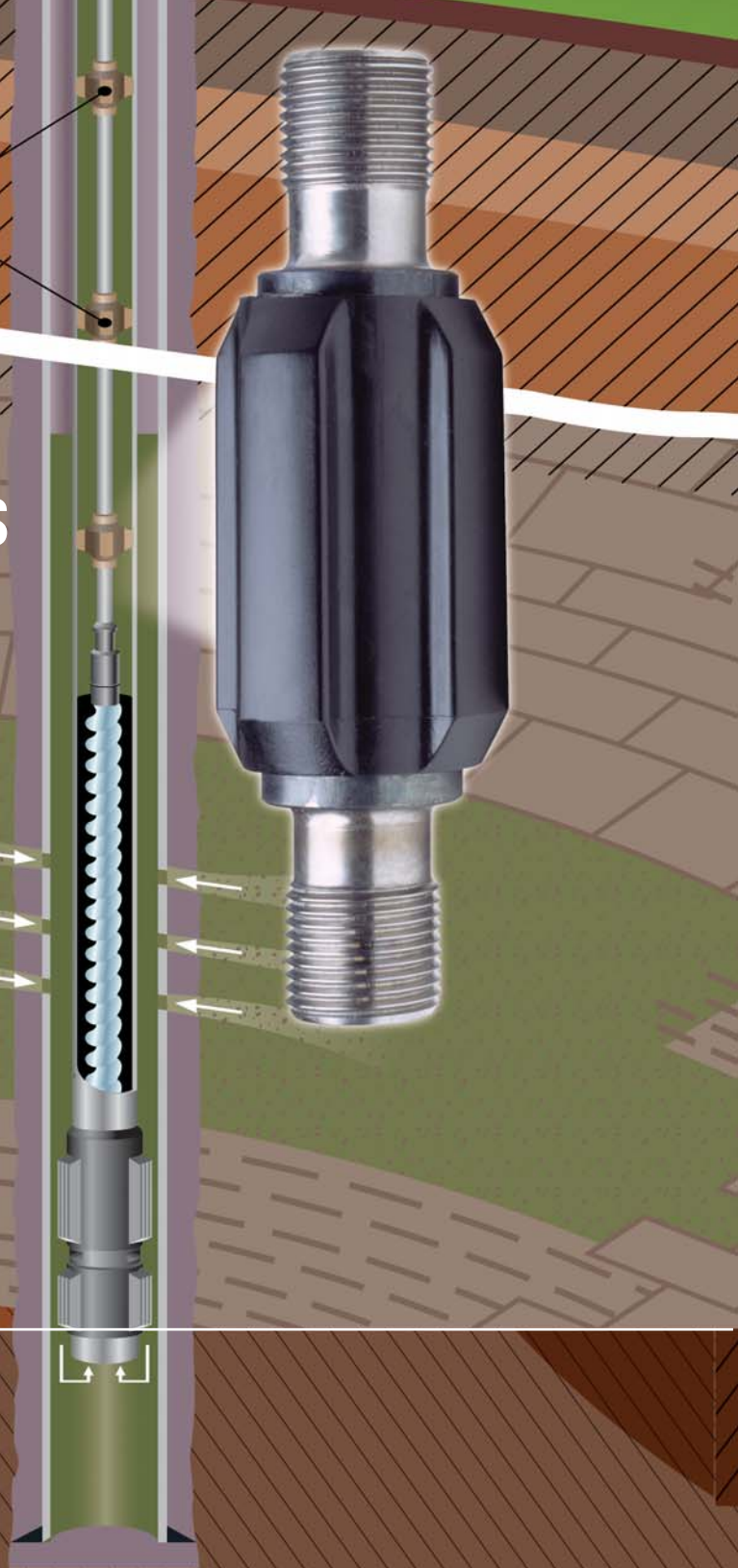

Proven Stabilizing Action

- Stabilizes rod string
- Eliminates or reduces tubing wear
- Easily installed with no special tools

Bringing solutions to the surface since 1989.



20 YEARS OF INNOVATION
1989 - 2009

KUDU Sucker Rod Centralizers

KUDU's Sucker Rod Centralizers eliminate rod coupling wear and utilize a non-rotating sleeve design that is tapered for rod tripping. The Sucker Rod Centralizers reduce torque in deviated wells and lower work over frequency. Rotational rubbing and rod wear are reduced or eliminated by using KUDU's non-rotating Centralizer.

In abrasive conditions KUDU recommends centralizing the sucker rod string wherever the coupling or tubing loading exceeds 25 lbs. In non-abrasive conditions, KUDU recommends centralizing wherever the loading would exceed 50 lbs. Centralizers should be installed to keep the loading below 100 lbs on each centralizer.

KUDU also recommends the use of a minimum of five non-rotating Centralizers on vertical wells to prevent the following two issues:

1. The eccentric motion of the rotor from being transmitted to the rod string. One centralizer should be placed twelve feet ABOVE the rotor head plus one on top of the each of the two full sucker rods.
2. Any wobble in the rod string from being transmitted to the polished rod, which reduces the life of the seal or stuffing box, place one centralizer at the bottom of the polished rod and one at the bottom of the adjacent sucker rod.

KUDU's Complete PCP System

KUDU provides the perfect fit for any environment with the complete package including the PC Pump, KUDU Drivehead, Power Unit and the PCP Well Manager. KUDU's customer focused approach encompasses exceptional design, superb service and technical training for customers.

Features

- Regular Spindle and API Coupling for normal service (low sand). Spindle is made of 4140 HTSR tool steel, heat treated, stress relieved and induction surface hardened to resist abrasion.
- Chromed Spindle and Chromed Tipped Rod Couplings for severe conditions (high sand).
- The Sleeve is made of Kevlar-Nylon co-polymer. It is tough and hard enough to resist sand embedment.
- Impervious to aromatics and H₂S, with a temperature rating of 120°C (250°F).

Precautions

- Sleeves can wear out rapidly in severe conditions if over loaded.
- Over loading in abrasive conditions can wear out spindles, even if they are chromed.
- Unchromed couplings can wear out rapidly at high speed with low sand cuts or at nominal speed with high sand cuts.
- Rod count will change with large number of centralizers installed (add to string length).



Contact your local KUDU representative or visit our website to find a distributor near you. All information is considered accurate and up to date at time of printing. KUDU reserves the right to amend the contents of this document at any time. KUDU does not warranty manufacturers claims.

Australia
Tel: +07 3842 3105
Email: australia@kudupump.com

Kazakhstan
Tel: +7 727 259 7630
Email: kazakhstan@kudupump.com

Middle East
Tel: +968 9550 1017
Email: middleeast@kudupump.com

Russia
Tel: +7 342 249 8594
Email: russia@kudupump.com

South Central America & Mexico
Tel: +1 281 296 1602
Email: southamerica@kudupump.com

North America
Toll Free: +1 800 642 5519

KUDU INDUSTRIES INC.
HEAD OFFICE & MANUFACTURING
9112 – 40th Street SE
Calgary, AB Canada
T2C 2P3
Tel: +1 403 279 5838

www.kudupump.com